



DON'T FORGET

These instructions can be found in color and expandable at QA1.net

Technical Support Line: (952) 985-5675 Email: sales@QA1.net

INSTALLATION INSTRUCTIONS

QA1 P/N R156-170, R256-170, R356-170 Rear Suspension
1967-1969 GM F-Body

TOOLS AND SUPPLIES REQUIRED

- Floor Jack
- Two Jack Stands
- Mig Welder capable of ¼" penetration
- SAE Wrench Set
- Anti-seize
- Angle Grinder
- Ratchet & Socket Set
- Torque Wrench
- Tire Chocks
- Four Large C-Clamps

Note:

This installation requires welding near the fuel tank and fuel lines on the passenger side frame rail. This installation can be completed with the fuel system in place and **closed** (no open lines), or the fuel tank and lines can be removed, as long as any portion of the open fuel system does not emit fuel vapors near the welding area. With either method, it is recommended that the fuel tank be as close to empty as possible before beginning the installation.

Consider upgrading this suspension with the QA1 Rear Anti-Roll Bar (p/n 52827) and Subframe connectors (p/n 52093)

Removal

1. Measure the beginning ride height of the car from the fender down through the center of the wheel to establish the original ride height.
2. Measure the front to rear wheelbase from the center of the front hub to the center of the rear hub as a base reference.
3. Disconnect the vehicle battery as welding to the frame will be necessary for installation.
4. Raise the rear of the car and support it at the frame rail with jack stands on a stable surface.
5. Remove the rear exhaust section.
6. Remove the upper shock connection.
7. Mark the driveshaft phasing at the pinion and remove the driveshaft from the car.
8. Remove the brake line connection at the driver side floor pan bracket. **(Figure 1)**
9. Flip the brake line junction bracket so that the brake support is below the mounting bolts. **(Figure 2)**
10. Remove the rear sway bar (if equipped)
11. Loosen the front and rear leaf spring mounts. Do Not Remove At This Time.
12. Lightly support the axle using a jack or by setting the car slightly on the ground to contain the energy of the leaf springs.
13. Remove the front and rear leaf spring hardware and remove the axle from the car. (Figures 3 & 4)

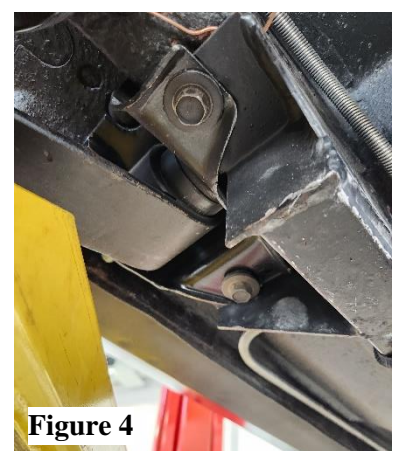
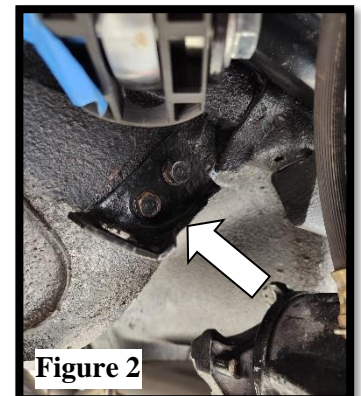

If Using A Vehicle Lift-

Re-check the vehicle weight balance now that the heavy axle has been removed. Reposition the lift arms or use a pole jack at the front of the vehicle for stability.

14. Remove the front leaf spring mounts from the leaf springs. Mark the leaf spring mounts as they are right/left specific. **(Figure 5)**



Installation

Note:

This installation process will require the suspension to be mocked up at ride height before the axle is removed for welding the tabs to the axle and the cross-member welded into the car. All listed torque values for the hardware will be used upon final installation of the suspension.

1. Identify the right/left axle mounts. **(Figure 6)**
2. Bolt the axle brackets to the axle using included u-bolts and hardware. Evenly torque to 50 lb. ft. **(Figure 7)**

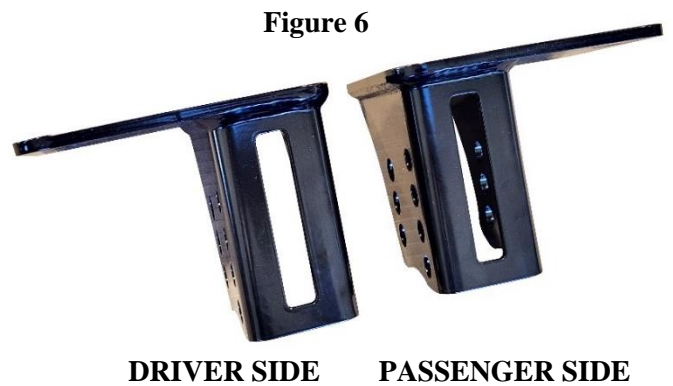

Note:

Mono-leaf cars will need to shorten the extra threads of the u-bolts that protrude within the bracket, leaving plenty of clearance for the lower trailing arm. Be sure to thread the nut onto the threads before cutting to allow the nut to clean the threads as it is removed. **(Figure 8)**

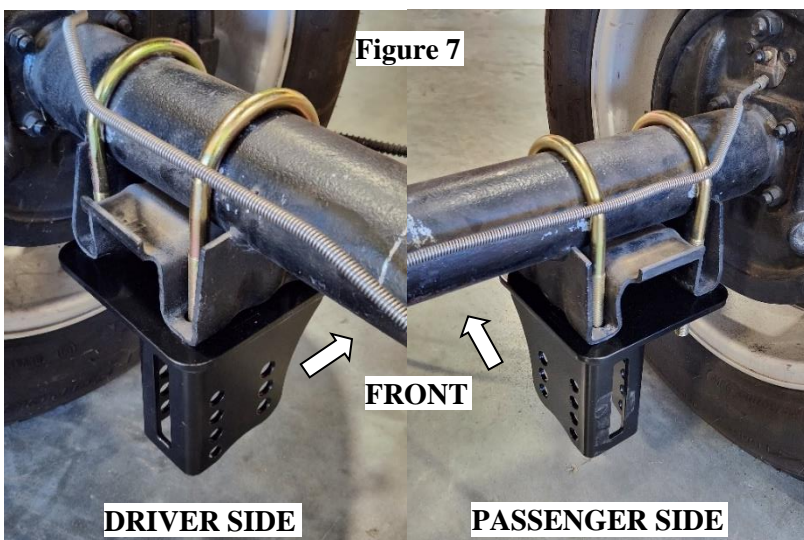

3. Identify the left/right "L" shaped lower shock mounts which will angle the shock mount inboard. These "L" shaped brackets can be mounted dependent on the desired ride height:

Note:

The ride height range of this suspension is 2" higher than stock to 3" lower than stock. The lower shock brackets can be mounted in the up position (for higher ride heights) (**Figure 10**) or down position (lowered ride heights) (**Figure 9**) depending on the desired ride height range. There are two sets of mounting holes on the axle brackets. Cars with Multi-leaf axles will use the upper set of holes with the brackets in the down position, while cars with a Mono leaf axle will be able to use either set depending on ride height. At ride height the shock should measure 13.5" to 14.5", measured center/center on the mounting bolts.



4. With the desired final ride height in mind, install the "L" shaped shock mounts to the axle bracket using 7/16" x 1-1/4" hardware, with two washers and one nyloc nut per connection. Torque to 50 lb. ft.
1. Remove the mounts holding the fuel lines to the passenger side frame. The fuel lines may remain in place while the

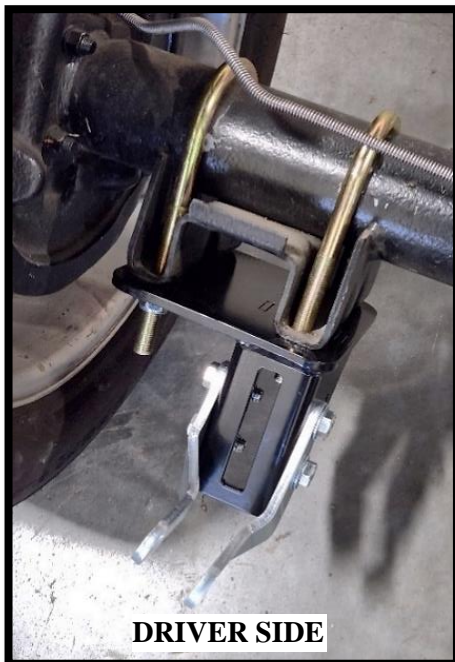

crossmember is fitted to the car but will need to be pushed up out of the way as much as possible. Fuel lines should not be opened anywhere near the frame rail unless they will be fully removed during welding.

2. Place the QA1 crossmember in place using clamps. The center of the crossmember will tuck tight to the floor pan corner with the front flanges sitting 1/4" above the bottom of the frame rail. **(Figures 11 & 12)**
3. Mark the areas of the frame where the crossmember flanges will be welded.

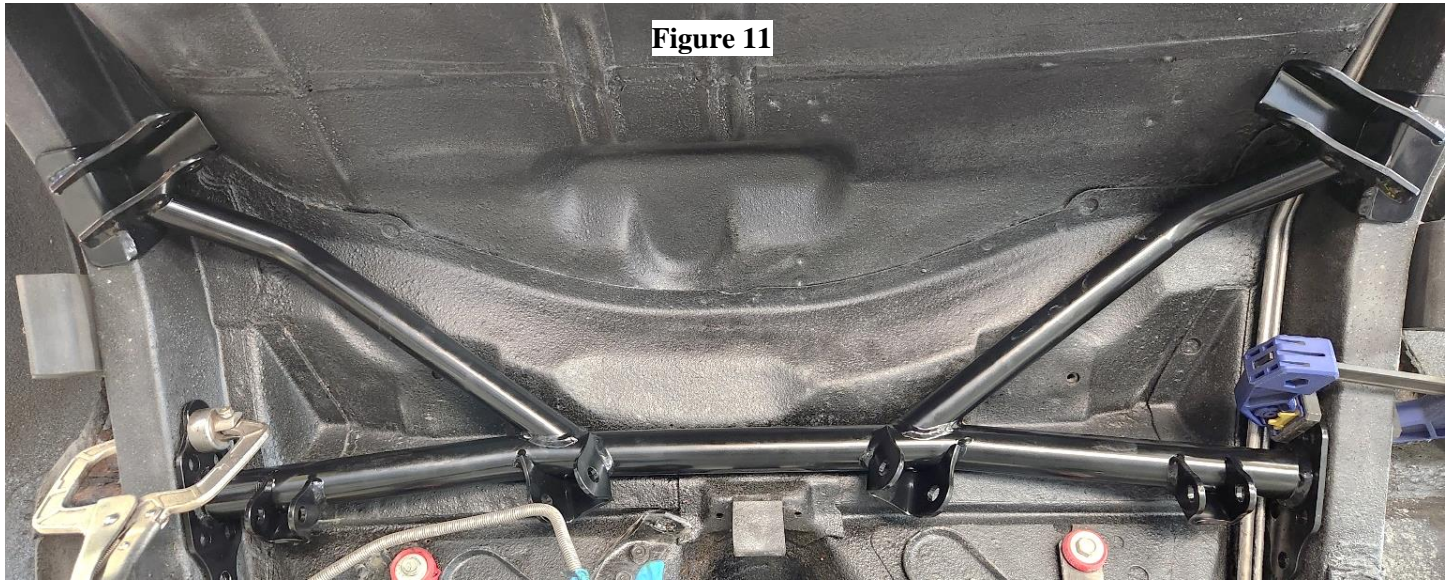

Figure 11

4. Remove the crossmember and sand the marked frame rail areas to bare metal. Weld-through primer can be applied to the frame rails and the frame-facing flange faces to prevent future corrosion. **(Figure 13)**

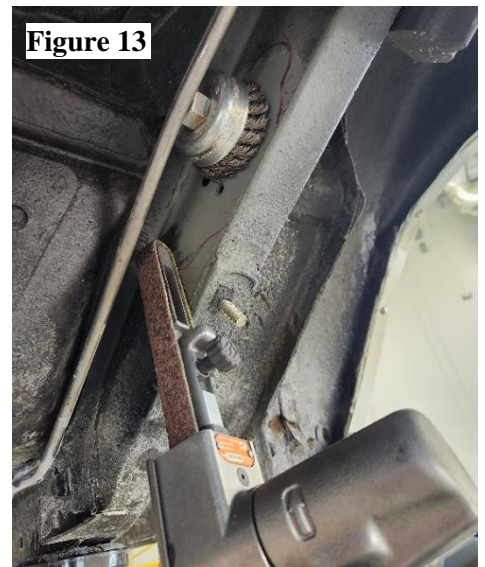
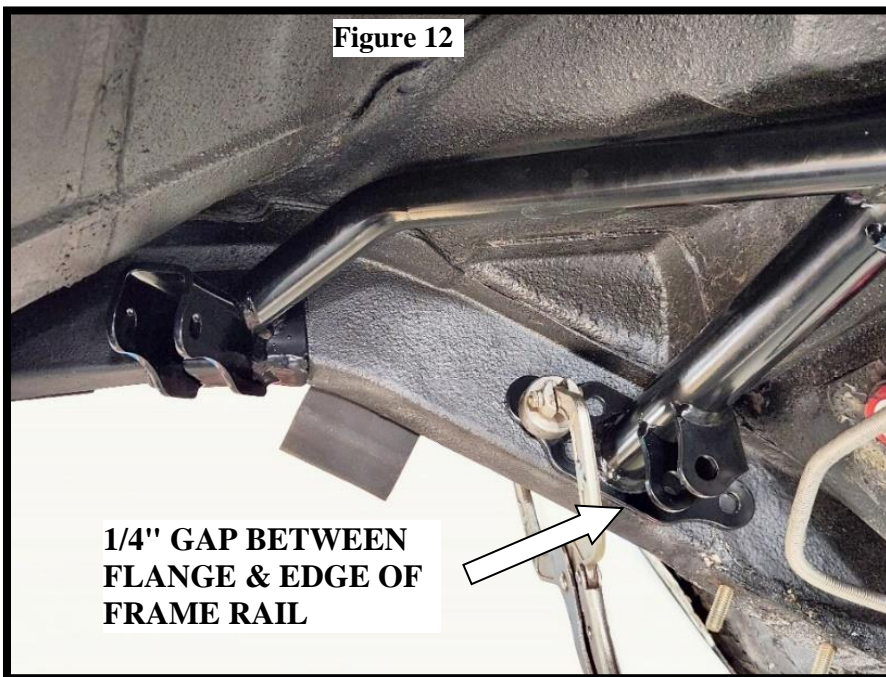

Figure 13

5. Reinstall the crossmember to the correct position with the center tucked tightly to the floor pan with 1/4" of frame rail below the front flange. **(Figure 13)**
6. Using a welder capable of 1/4" penetration, plug weld all holes in the front flanges and the flange edges of the rear flanges. **(Figure 14 & 15)** Alternate sides during welding to prevent overheating/warping of the flanges or frame rails. **Using compressed air to cool each weld and eliminate the chance of inner frame rail fires is highly recommended.**

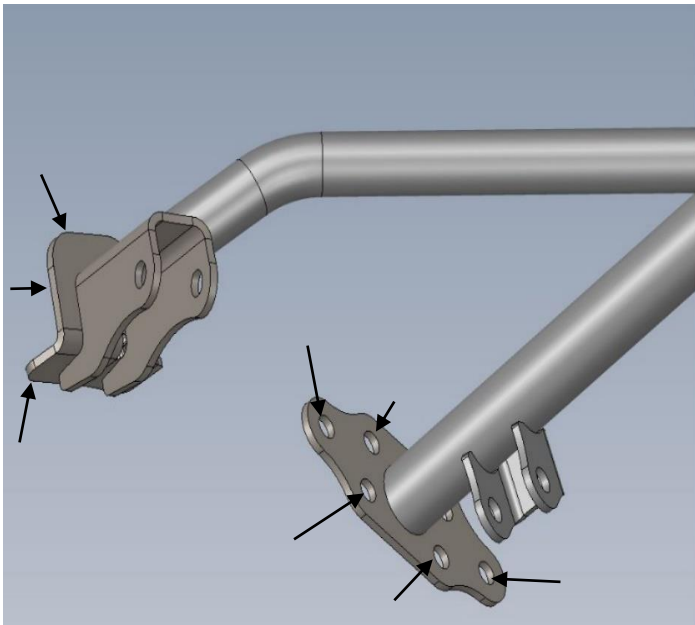

Figure 14

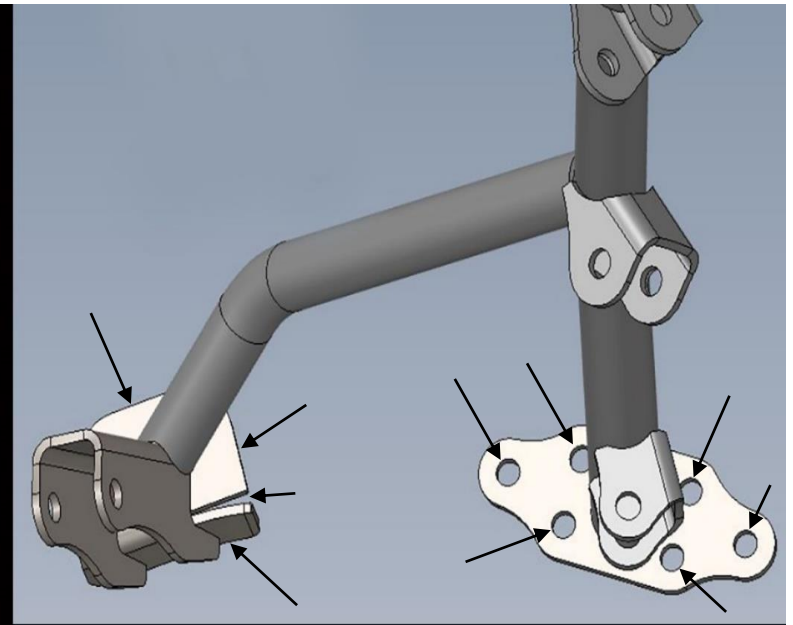

Figure 15

7. Prime and paint the finish-welded flanges of the crossmember.
8. Verify the QA1 lower trailing arm length is 25-5/16" center to center on the mounting bolt holes.



9. Re-using the front leaf spring brackets from the vehicle, bolt the fixed bushing end of the QA1 lower trailing arms to the mounts using one 1.3" wide black anodized spacer on the outboard side of the mount. **(Figure 16)** This connection can only be accomplished with the leaf brackets removed from the car. Secure using 1/2"x 5" bolt with two washers and one nyloc nut per side. This connection should be final torqued at ride height to 75 lb. ft.

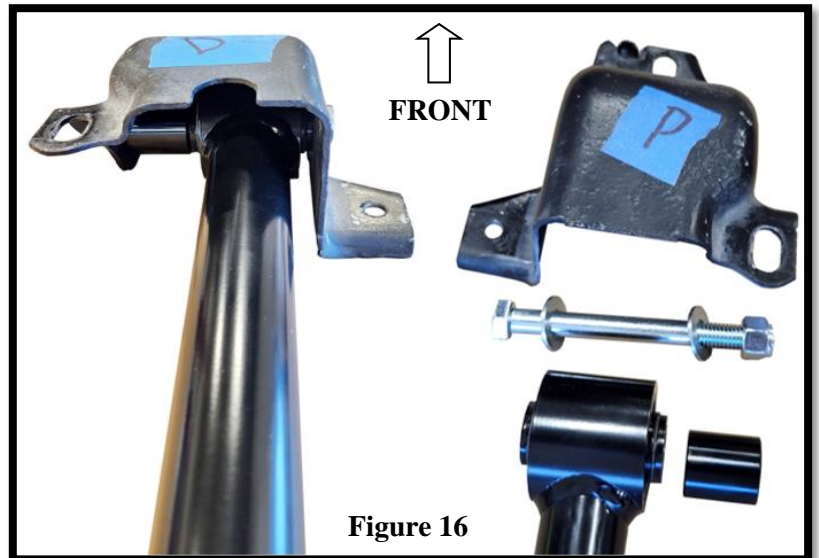

Figure 16

10. Replace the factory u-nuts at the front leaf spring mount with the included new u-nuts. **(Figure 17)**



Figure 17

- With the lower trailing arm attached to the factory front leaf spring mounts, reinstall the front leaf spring mounts onto the vehicle using the included new J-nuts (**Figure 17**) and 3/8" hardware. Torque to 30 lb. ft.
- Verify the QA1 upper trailing arms are 11-1/4" center to center on the mounting bolt holes.



- With one SG12-88 spacer on each side of the red anodized upper trailing arms, install the upper trailing arm into the inner mounting tabs at the front of the crossmember. (**Figure 18**) Secure using 1/2"x 3.25" hardware with two washers and one nyloc nut per connection. Torque to 50 lb. ft.
- Identify the left/right weld-in mounts for the upper trailing arm to axle connection and install the red anodized upper trailing arms into the top hole with one SG12-88 spacer on each side of the rod end. Secure using 1/2"x 3.25" hardware with two washers and one nyloc nut per connection. The upper trailing arms should now be hanging from the crossmember with weld-in brackets in preparation for the axle mock-up. (**Figure 19**)

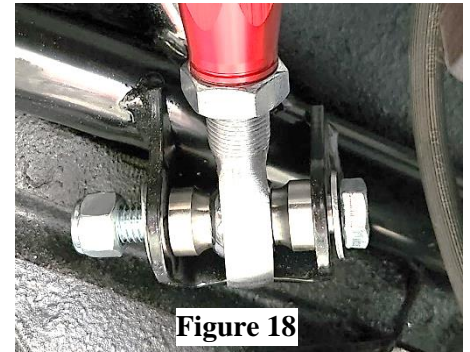

Figure 18

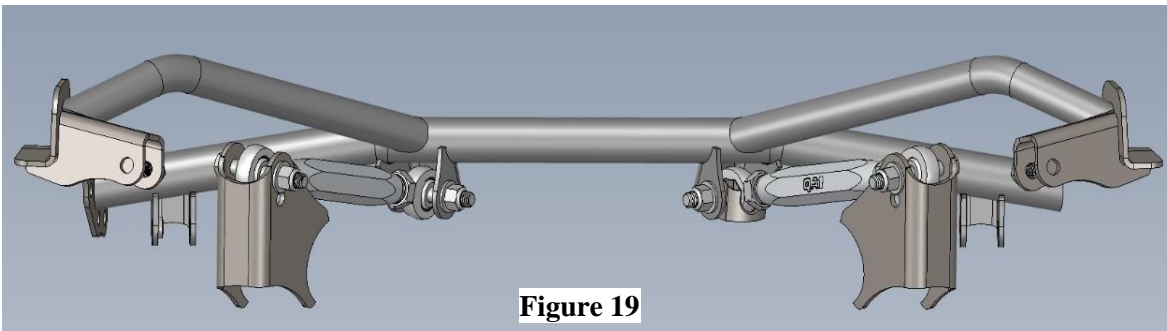

Figure 19



- Mount the coil-over shocks (without springs for mock up) onto the rear crossmember mounts using 1/2" x 2-3/4" hardware with two washers and one nyloc nut per connection. (**Figure 20**)

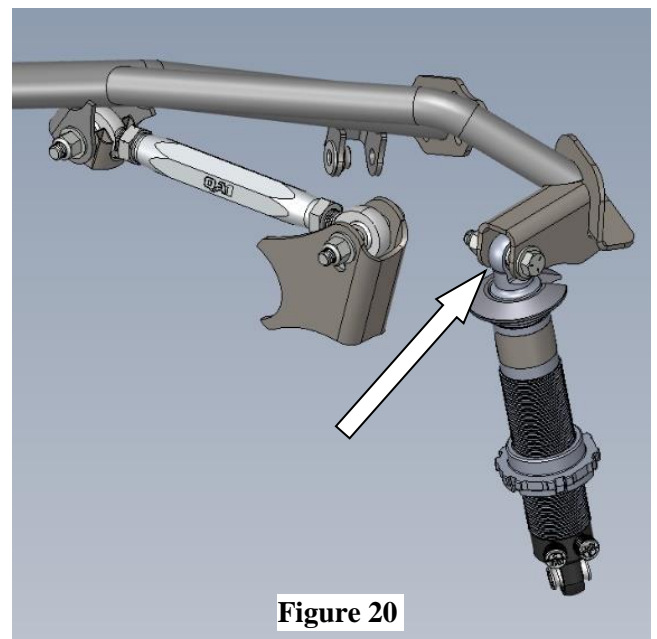
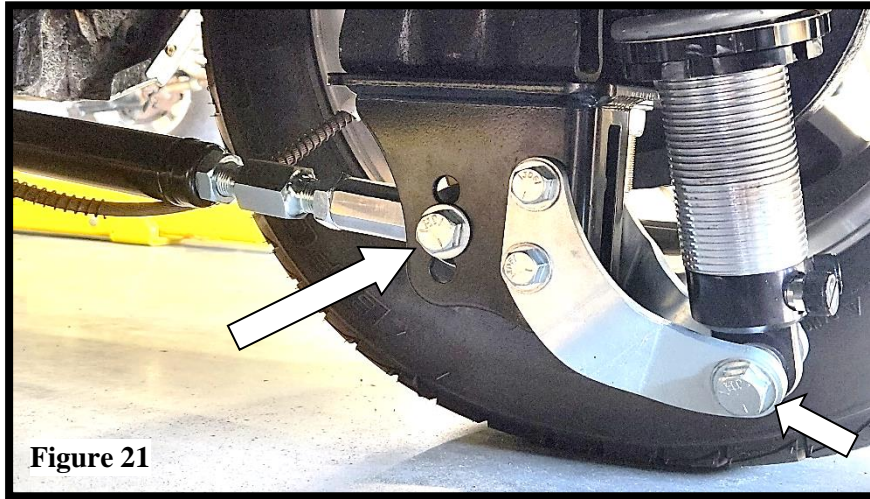
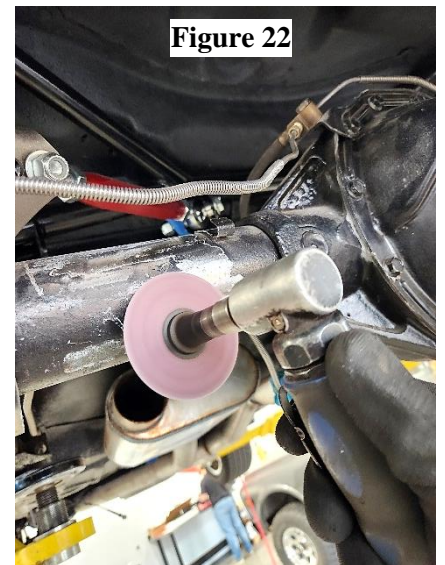

Figure 20

16. Roll the axle into place and support the pinion with a jack stand so that the axle does not roll.
17. Connect the lower trailing arms to the center hole of the axle mounts using 1/2" x 3.25" hardware, with two washers and one nyloc nut. Torque to 75 lb. ft. **(Figure 21)**
18. Attach the lower shock mount to the "L" brackets on the axle using 1/2" x 2.75" hardware, with two washers and one nyloc nut. Torque to 50 lb. ft. **(Figure 22)**



19. With the upper trailing arms swung above the axle, position the axle to your desired ride height.
20. With the upper trailing arm mounts resting on the axle, lift the arms up and clean the axle tube to bare metal where the mounts will be welded. **(Figure 22)**
21. Center the axle between the frame rails (at your desired ride height) by measuring the frame rail to back of hub distance on both sides of the vehicle.
22. Measure the wheelbase from the front to rear hubs to compare to your beginning measurement to ensure the axle is true. Slight adjustments can be made after final installation by adjusting the lower trailing arm length.
23. Adjust the rotation of the pinion angle so that the pinion is 1° down from transmission angle.



24. Measure the fender ride height through the center of the wheel so that this ride height can be duplicated after final assembly. Measuring the axle to the bottom of frame rail can serve as a secondary measurement. **(Figure 23)**



25. Double check all clearances and measurements before continuing.

26. Install the 3D printed rod end braces (a.k.a. Barbie Chairs) onto the front and rear rod ends of the upper trailing arms with the axle mounts resting on the axle. These braces will support the rod end connection while welding. **(Figure 24)**

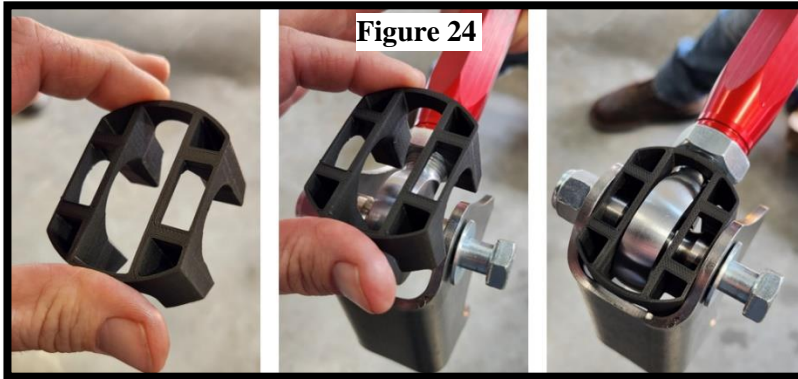

27. Double check that your axle is at the desired ride height, centered within the frame rails, and your pinion angle is still set to 1 degree negative (down) before tack welding the upper trailing arm mounts to the axle. **(Figure 25)**

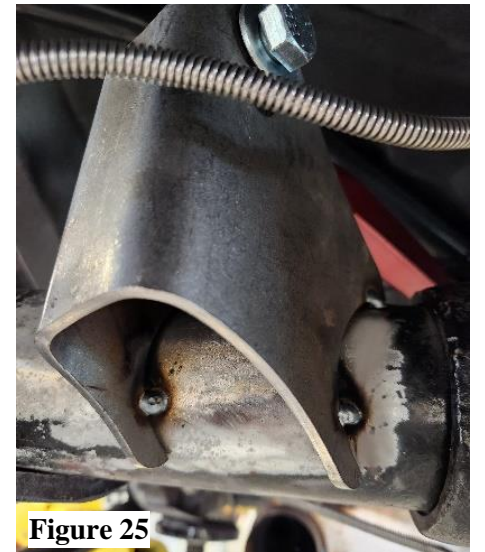

28. Double check all measurements again before removing the axle from the vehicle for final welding.

29. Fully weld the outer edges of the axle tabs and the accessible portion of the inner tabs. It is recommended not to fully weld the inner tabs as to not introduce an excessive amount of heat into the tab. **(Figures 26)**



30. Coat the axle as desired to prevent future corrosion.

31. Install the included block-off plates to the factory upper shock mounts using the included 5/16 x 3/4" bolts and washers. Torque to 18 lb. ft. These plates will prevent road debris from entering the trunk. **(Figure 27)**



32. Reinstall the axle into the vehicle and reconnect the following:

CONNECTION	TORQUE SPEC
Lower Trailing Arm to Axle	75 lb. ft.
Lower Shock Mount to Axle	50 lb. ft.
Upper Trailing Arm to Axle	75 lb. ft.

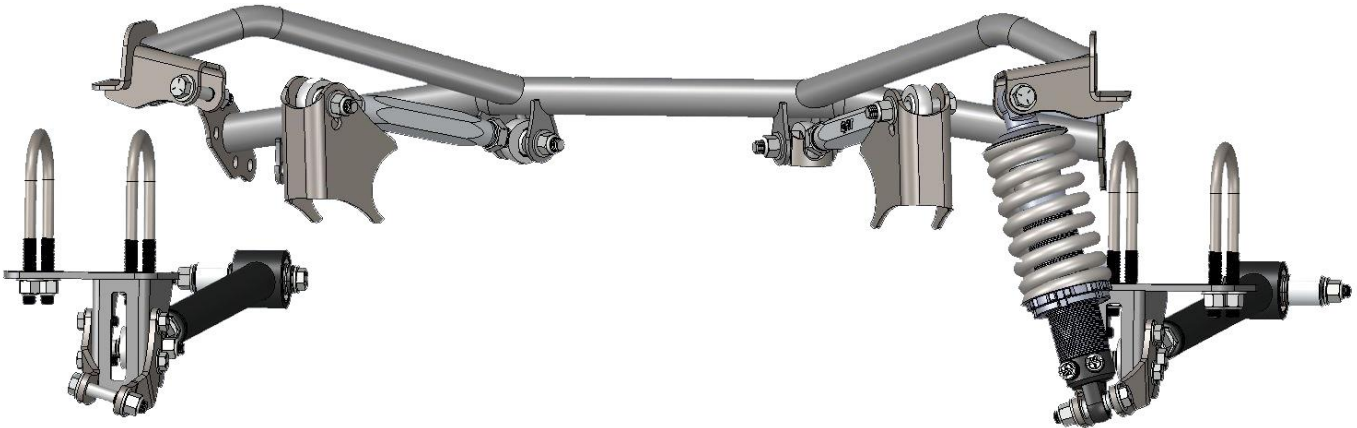

33. Reinstall the brake lines and bleed the system.

34. Reinstall the exhaust, and driveshaft.

35. Refer to the coil-over assembly instructions included with the shocks.

36. Adjust the spring seats on the coil-over shocks so that 2" of threads are under the adjustment collars. This will be a good initial setting to set the car down and check the ride height. Re-adjust the collars with weight off of the car to the desired ride height before tightening the lower locking collar into the spring seat collar. At final ride height the shock should measure 13.25" to 14.5", measured center/center on the mounting bolts. Refer to Figures 9 & 10 if a bracket orientation change is needed to both achieve the desired ride height and the shock length recommendation. Set the shock adjustment knob(s) for the intended driving to be done.

37. Double check all work. It's a basic and overlooked practice that distinguishes the most effective builders from the rest.



As shown: 16x8 American Racing, 4.07" Back space. Front: 225/50/16 Rear: 255/60/16

- What is the max wheel and tire size?
 - Tire diameter depends on ride height setting, but generally a 30" tall drag tire can work at higher ride heights.
 - Tire width is limited by factory wheel tubs. Four link alone will not allow wider wheel or tire package
 - With mini tubs 335mm on 1969 cars, 315mm on 67-68 cars
 - Widest tires may require custom back spacing, or narrowed rear axle

A professional four wheel alignment is required before driving the vehicle.

Shock Valving Adjustments

	<i>Shocks with one adjuster knob:</i>	<i>Shocks with two adjuster knobs:</i>	
		<i>Compression</i>	<i>Rebound</i>
Drag Racing:	4-10 clicks	7-12 clicks	2-8 clicks
Nice ride and handling:	0-6 clicks	0-6 clicks	2-8 clicks
Firm ride & improved handling:	6-12 clicks	6-12 clicks	8-14 clicks
Aggressive handling:	13-18 clicks	13+ clicks	14-18 clicks



READ ALL INSTRUCTIONS CAREFULLY AND THOROUGHLY PRIOR TO STARTING INSTALLATION. PRODUCTS THAT HAVE BEEN INSTALLED ARE NOT ELIGIBLE FOR RETURN. USE THE PROPER JACKING LOCATIONS. DEATH OR SERIOUS INJURY CAN RESULT IF INSTRUCTIONS ARE NOT CORRECTLY FOLLOWED. A GOOD CHASSIS MANUAL, AVAILABLE AT YOUR LOCAL PARTS STORE, MAY ALSO AID IN YOUR INSTALLATION.

• **DISCLAIMER / WARRANTY** •

QA1 WARRANTS THAT THE PRODUCTS WILL BE FREE FROM DEFECTS IN MATERIAL AND WORKMANSHIP FOR ONE YEAR FROM DATE OF SALE TO THE ORIGINAL PURCHASER. QA1 MAKES NO OTHER WARRANTY OF ANY KIND, EXPRESS OR IMPLIED. QA1 SHALL HAVE NO OBLIGATION UNDER THE FOREGOING WARRANTY WHERE THE DEFECT IS THE RESULT OF IMPROPER OR ABNORMAL USE, YOUR NEGLIGENCE, VEHICLE ACCIDENT, IMPROPER OR INCORRECT INSTALLATION OR MAINTENANCE, NOR WHEN THE PRODUCT HAS BEEN REPAIRED OR ALTERED IN ANY WAY. QA1'S LIABILITY IN THE CASE OF DEFECTIVE PRODUCTS SUBJECT TO THE FOREGOING WARRANTY SHALL BE LIMITED TO THE REPAIR OR REPLACEMENT, AT QA1'S OPTION, OF THE DEFECTIVE PRODUCTS.

THE USER UNDERSTANDS AND RECOGNIZES THAT RACING PARTS, SPECIALIZED STREET ROD EQUIPMENT, AND ALL PARTS AND SERVICES SOLD BY QA1 ARE EXPOSED TO MANY AND VARIED CONDITIONS DUE TO THE MANNER IN WHICH THEY ARE INSTALLED AND USED. QA1 SHALL BEAR NO LIABILITY FOR ANY LOSS, DAMAGE OR INJURY, EITHER TO A PERSON OR TO PROPERTY, RESULTING FROM THE INSTALLATION, DIRECT OR INDIRECT USE OF ANY QA1 PRODUCTS OR INABILITY BY THE BUYER TO DETERMINE PROPER USE OR APPLICATION OF QA1 PRODUCTS. WITH THE EXCEPTION OF THE LIMITED LIABILITY WARRANTY SET FORTH ABOVE, QA1 SHALL NOT BE LIABLE FOR ANY CLAIMS, DEMANDS, INJURIES, DAMAGES, ACTIONS, OR CAUSES OF ACTION WHATSOEVER TO BUYER ARISING OUT OF OR CONNECTED WITH THE USE OF ANY QA1 PRODUCTS. MOTORSPORTS ARE DANGEROUS; AS SUCH, NO WARRANTY OR REPRESENTATION IS MADE AS TO THE PRODUCT'S ABILITY TO PROTECT THE USER FROM INJURY OR DEATH. THE USER ASSUMES THAT RISK!

DEDICATED TECH SUPPORT

QA1 is dedicated to providing quality support and instructions. We employ passionate racers and car enthusiasts that know our products and the industry to better serve you.

CHECK US OUT ON YOUTUBE!



- Frequently Asked Questions
- Quick Tips
- Install Information
- Tuning and Repair Guides
- Other Technical Information



- [linkedin.com/company/qa1](https://www.linkedin.com/company/qa1)
- [instagram.com/qa1motorsports](https://www.instagram.com/qa1motorsports)
- [facebook.com/qa1motorsports](https://www.facebook.com/qa1motorsports)

[youtube.com/qa1tech](https://www.youtube.com/qa1tech)

www.qa1.net/tech