



DON'T FORGET
These instructions can be found in color and expandable at QA1.net

Technical Support Line: (952) 985-5675 Email: sales@QA1.net

INSTALLATION INSTRUCTIONS

QA1 P/N 52093,
'67-'69 CAMARO/FIREBIRD BODY SUBFRAME CONNECTOR KIT

TOOLS AND SUPPLIES REQUIRED

- Floor Jack
- Jack Stands
- Ratchet & Socket Set
- Torque Wrench

PRE-INSTALLATION NOTES-

Will not fit convertible models.

QA1 subframe connectors require solid body bushings. Refer to the install instructions included with the solid bushing kit for installation before subframe connectors are installed.

These instructions show photos of a vehicle equipped with the QA1 four-link conversion. QA1 subframe connectors will work with leaf springs or QA1 four-link.



INSTALLATION-

1. Raise the vehicle on a level surface and support both front and rear frame rails on jack stands, keeping in mind that the front leaf spring mounts will need to be removed for this installation.
2. Support the weight of one side of the axle. QA1 recommends installing one side at a time.
3. Remove the three bolts holding the front leaf spring mounts to the vehicle. The factory mounts and hardware can be discarded. **(Figure 1)**
4. Remove the three factory u-nuts from the mount location and replace with the included u-nuts. **(Figure 2)**

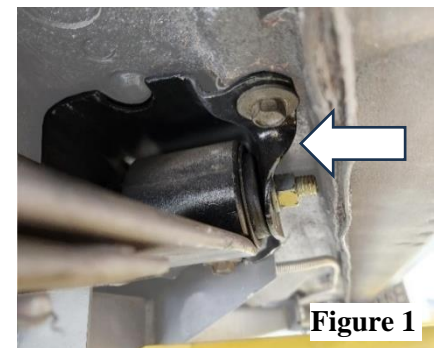

- Identify the included driver (left) and passenger (right) side leaf spring mounts. **(Figure 3)**
- Secure the leaf spring (or QA1 trailing arm) to the new leaf spring mount with the 1/2" x 5" bolt head towards the inboard side of the vehicle using only one washer under the nyloc nut. Torque to 75 lb. ft. This bolt is not accessible once the mounts are installed onto the vehicle. **(Figure 4)**

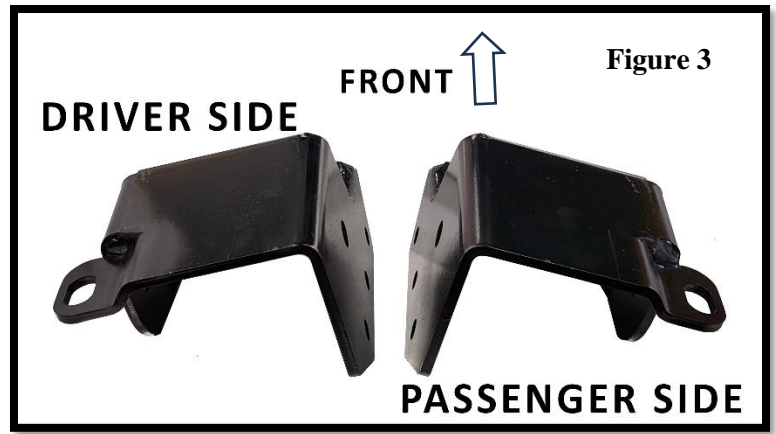

- Install the included leaf spring mount to the vehicle using the included 3/8" x 1.25" flanged bolt with one washer per connection. Leave these three bolts loose for now. **(Figure 5)**
- Remove the bolt, washer, and bushing at the rear of the front subframe. **(Figure 6)**

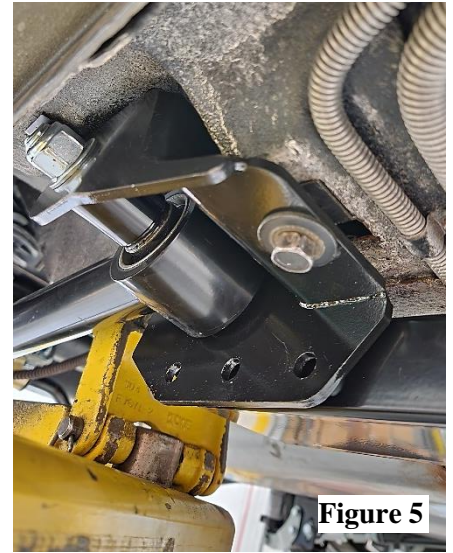
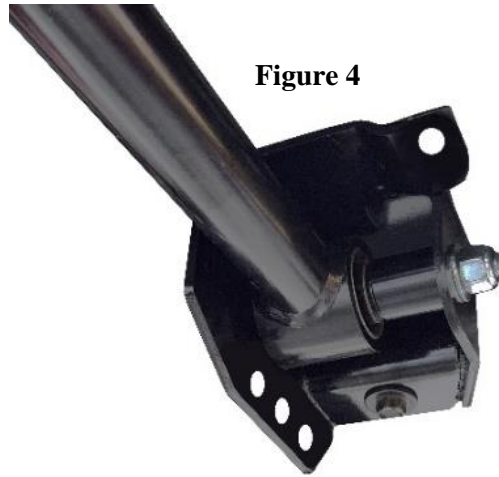

- Attach the front of the subframe connector to the front subframe using the bolt removed in the previous step. **(Figure 6)** This step is to simply hold the subframe connector in place. These subframe connectors require QA1 solid body bushings which is a separate installation that should be completed before the subframe connectors. Torque to 100 lb. ft. at the completion of this installation with the suspension loaded.

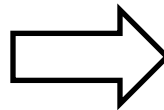

10. Attach the rear of the subframe connector to the inboard side of the leaf spring mount using the included 3/8" x 1" bolts, with one washer under the bolt head and one flanged nut per connection. Begin with the front connection. A piece of paper towel in a 9/16" wrench will help hold the nut while positioning it inside the subframe connector. (Figure 7, 8, 9)

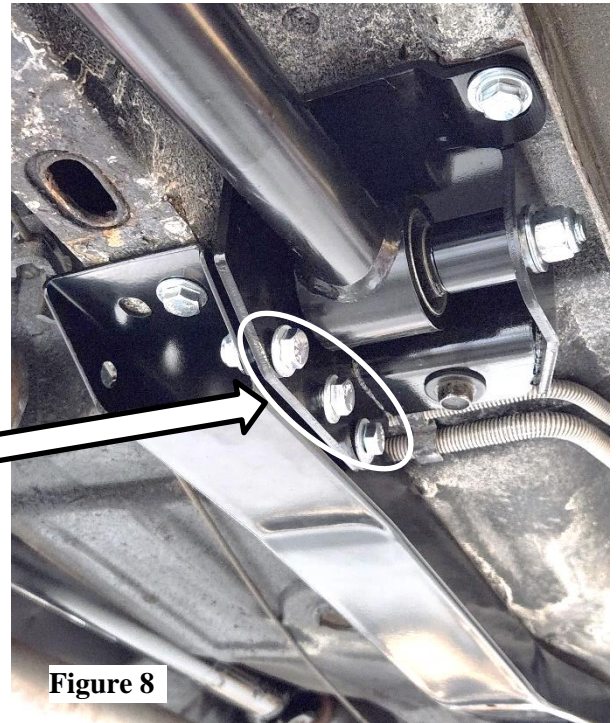
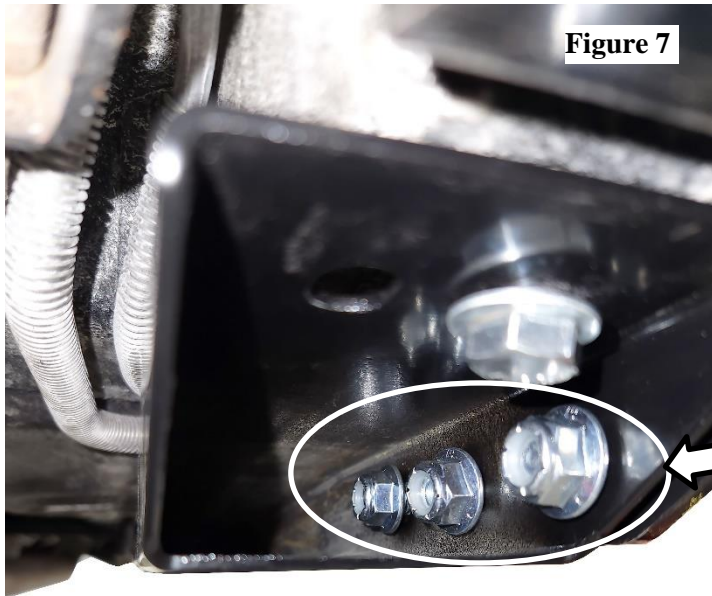

11. With the suspension loaded, evenly torque the three vertical bolts holding the leaf mount and subframe connector to 30 lb. ft. before torquing the subframe connector to leaf mount bolts to 30 lb. ft.
12. Repeat the installation on the opposite side of the vehicle.
13. Double check all work. It's a basic and overlooked practice that distinguishes the most effective builders from the rest.



BALLOON #	QTY/KIT	DESCRIPTION	QA1 ITEM #	WHERE USED
1	2	BOLT, HEX 1/2-13 X 5"	N/A	LEAF SPRING/ TRAILING ARM
2	2	WASHER, FLAT 1/2" SAE	9005-228	
3	2	NUT, NYLOCK, 1/2-13	9014-520	
4	6	BOLT, HEX, 3/8-16 X 1.0"	9012-229	TUBE TO BRACKET
5	6	NUT, HEX FLANGE NYLOCK 3/8-16	9014-545	
6	6	WASHER, FLAT 3/8" SAE HARDENED	9005-302	
7	2	BOLT, HEX FLANGE 3/8-16 X 1.75"	9012-354	2ND GEN SPACER/U-NUT

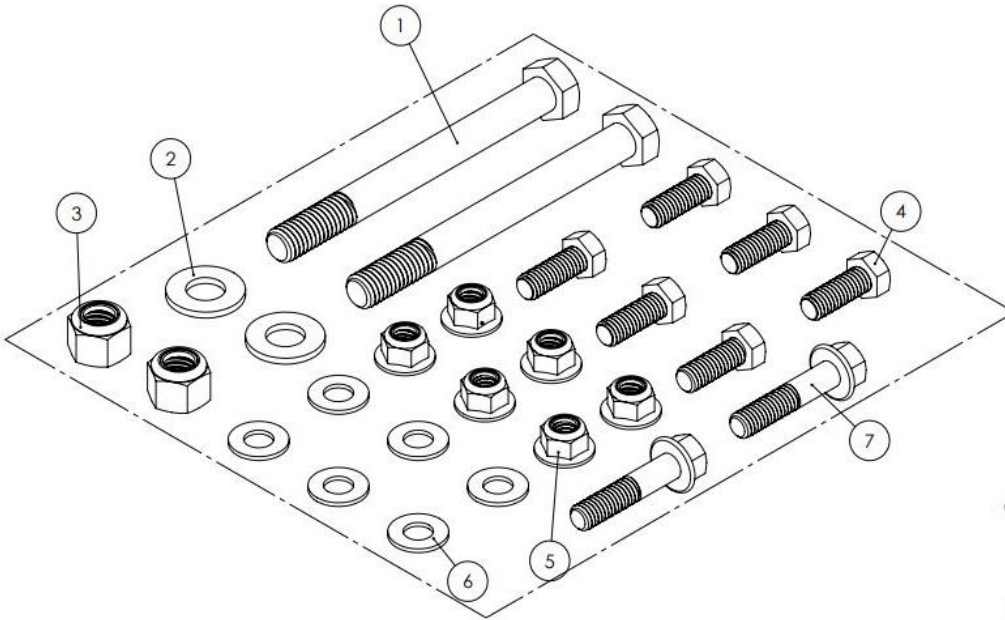

Torque Specs

1/2-13 Nuts & Bolts 75 ft/lbs

3/8-16 Nuts & Bolts 30 ft/lbs

BALLOON #	QTY/KIT	DESCRIPTION	2ND DESCRIPTION	QA1 ITEM #
1	6	BOLT, HEX FLANGE 3/8-16 X 1.25"	GRADE 5, CLEAR ZINC	9012-338
2	6	WASHER, FLAT 3/8 USS, HARDENED	.39" ID X 1.0" OD X .09", CLEAR ZINC/GALVANIZED	9005-317
3	6	U-NUT, EXTRUDED 3/8-16, SPECIAL	BLACK PHOSPHATE, GM 378276	9014-559

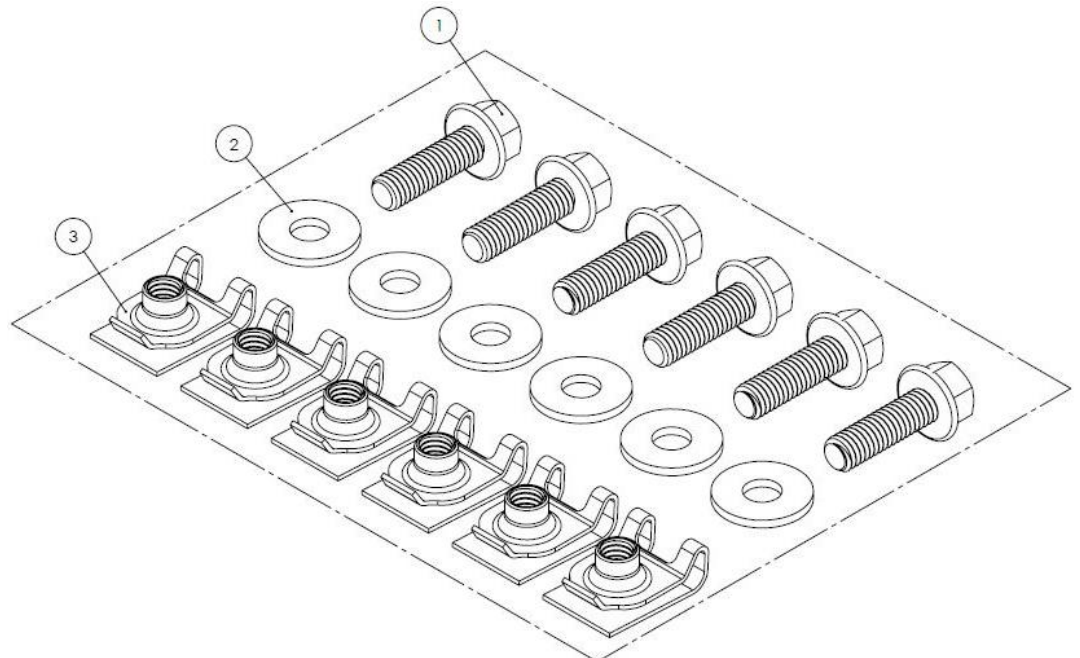

QA1

READ ALL INSTRUCTIONS CAREFULLY AND THOROUGHLY PRIOR TO STARTING INSTALLATION. PRODUCTS THAT HAVE BEEN INSTALLED ARE NOT ELIGIBLE FOR RETURN. USE THE PROPER JACKING LOCATIONS. DEATH OR SERIOUS INJURY CAN RESULT IF INSTRUCTIONS ARE NOT CORRECTLY FOLLOWED. A GOOD CHASSIS MANUAL, AVAILABLE AT YOUR LOCAL PARTS STORE, MAY ALSO AID IN YOUR INSTALLATION.

• **DISCLAIMER / WARRANTY** •

QA1 WARRANTS THAT THE PRODUCTS WILL BE FREE FROM DEFECTS IN MATERIAL AND WORKMANSHIP FOR ONE YEAR FROM DATE OF SALE TO THE ORIGINAL PURCHASER. QA1 MAKES NO OTHER WARRANTY OF ANY KIND, EXPRESSED OR IMPLIED. QA1 SHALL HAVE NO OBLIGATION UNDER THE FOREGOING WARRANTY WHERE THE DEFECT IS THE RESULT OF IMPROPER OR ABNORMAL USE, YOUR NEGLIGENCE, VEHICLE ACCIDENT, IMPROPER OR INCORRECT INSTALLATION OR MAINTENANCE, NOR WHEN THE PRODUCT HAS BEEN REPAIRED OR ALTERED IN ANY WAY. QA1'S LIABILITY IN THE CASE OF DEFECTIVE PRODUCTS SUBJECT TO THE FOREGOING WARRANTY SHALL BE LIMITED TO THE REPAIR OR REPLACEMENT, AT QA1'S OPTION, OF THE DEFECTIVE PRODUCTS.

THE USER UNDERSTANDS AND RECOGNIZES THAT RACING PARTS, SPECIALIZED STREET ROD EQUIPMENT, AND ALL PARTS AND SERVICES SOLD BY QA1 ARE EXPOSED TO MANY AND VARIED CONDITIONS DUE TO THE MANNER IN WHICH THEY ARE INSTALLED AND USED. QA1 SHALL BEAR NO LIABILITY FOR ANY LOSS, DAMAGE OR INJURY, EITHER TO A PERSON OR TO PROPERTY, RESULTING FROM THE INSTALLATION, DIRECT OR INDIRECT USE OF ANY QA1 PRODUCTS OR INABILITY BY THE BUYER TO DETERMINE PROPER USE OR APPLICATION OF QA1 PRODUCTS. WITH THE EXCEPTION OF THE LIMITED LIABILITY WARRANTY SET FORTH ABOVE, QA1 SHALL NOT BE LIABLE FOR ANY CLAIMS, DEMANDS, INJURIES, DAMAGES, ACTIONS, OR CAUSES OF ACTION WHATSOEVER TO BUYER ARISING OUT OF OR CONNECTED WITH THE USE OF ANY QA1 PRODUCTS. MOTORSPORTS ARE DANGEROUS; AS SUCH, NO WARRANTY OR REPRESENTATION IS MADE AS TO THE PRODUCT'S ABILITY TO PROTECT THE USER FROM INJURY OR DEATH. THE USER ASSUMES THAT RISK!

DEDICATED TECH SUPPORT

QA1 is dedicated to providing quality support and instructions. We employ passionate racers and car enthusiasts that know our products and the industry to better serve you.

CHECK US OUT ON YOUTUBE!



- Frequently Asked Questions
- Quick Tips
- Install Information
- Tuning and Repair Guides
- Other Technical Information



- [linkedin.com/company/qa1](https://www.linkedin.com/company/qa1)
- [instagram.com/qa1motorsports](https://www.instagram.com/qa1motorsports)
- [facebook.com/qa1motorsports](https://www.facebook.com/qa1motorsports)

[youtube.com/qa1tech](https://www.youtube.com/qa1tech)

www.qa1.net/tech